

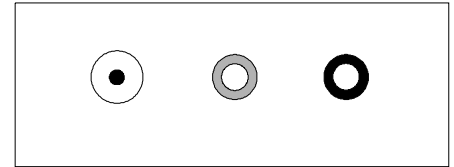



Keyboard Interface Video Text Overlay with Real Time Clock and Counter

The keyboard interface video text overlay unit allows control of a video text overlay from a PC keyboard. It uses the standard keyboard key mapping as illustrated below. Please read the entire document before using the overlay unit.

Connections

Before connecting the system to a power supply connect video in and video out via the phono connectors on the front panel. The PS/2 keyboard should be connected to the socket on the left of the enclosure. The unit will only operate with USB keyboards that have PS/2 functionality. The unit will not operate with a USB only keyboard connected via a USB to PS/2 adapter.





 9 - 12V DC video video
 Regulated in out

Front panel connectors

Power supply

The unit draws approximately 50mA and is designed to be powered from a 9 - 12V dc regulated power supply. The power supply used should be capable of providing 300 - 500mA according to the requirements of the keyboard and camera being used with the overlay unit. The keyboard used should not have a current draw greater than 200mA. For the enclosure option the power supply should be connected via the 2.1mm power connector on the front panel. Otherwise follow the pin out at the end of this document. The unit is designed to be powered from the same power supply as the camera so it does not have a power switch. The battery compartment of the enclosure cannot be opened.

WARNING! It is important to ensure correct connection of the video text overlay to the power supply and/or battery. Failure to observe correct power supply connection polarity may result in the electronic failure of the unit or in the battery bursting to cause personal injury and damage.

Program Operation

The program runs immediately the unit is connected to a power supply and the text display will appear within approximately 1 second. Without a video input signal the text display will be shown over a dark grey background video signal generated by the unit. The unit can automatically detect when a camera is connected and the text display will then be shown over the video signal from the camera. If the camera is disconnected the unit will automatically switch back to its internal video signal. The unit can also be set to default to its internal video signal regardless of whether a camera is connected. The unit will automatically detect the video standard, PAL or NTSC, at the time the unit is switched on. It will not detect a change in the video standard while the unit is powered, i.e. you cannot hot swap PAL and NTSC cameras. Disconnect the power, connect the new video input signal and connect the power again to select the new video standard. The font and text size are fixed and cannot be changed.

The basic operation of the text overlay unit is straightforward. A flashing underscore cursor indicates the current screen position. This cursor can be moved around the screen by the keyboard cursor keys. The cursor will wrap around the screen left and right, top and bottom. If no key is pressed then the cursor will disappear after approximately ten seconds. The video text overlay unit uses the standard UK keyboard mapping shown below if ordered from the UK and the standard international English keyboard mapping if ordered from elsewhere. Keyboard mappings of other countries or languages other than English can be ordered as special items.

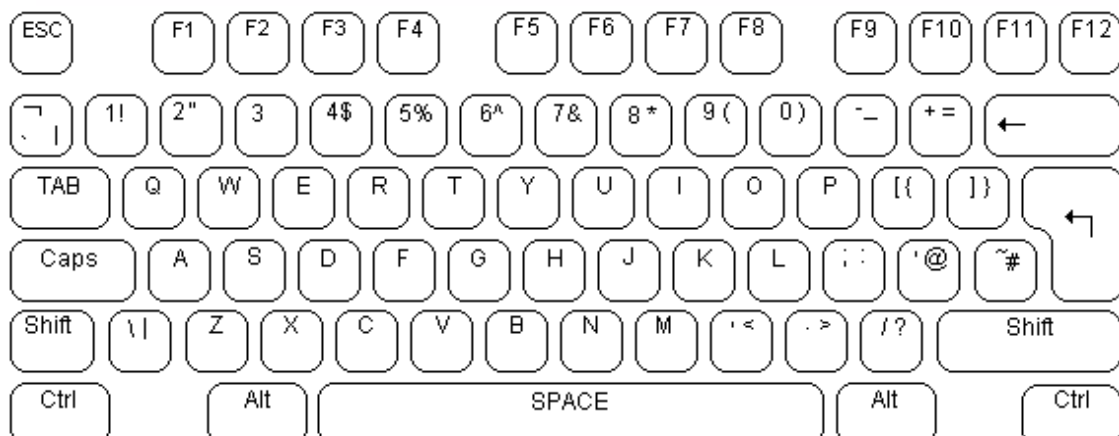

Standard UK keyboard mapping used by the video text overlay unit. By default all UK units are supplied with this.

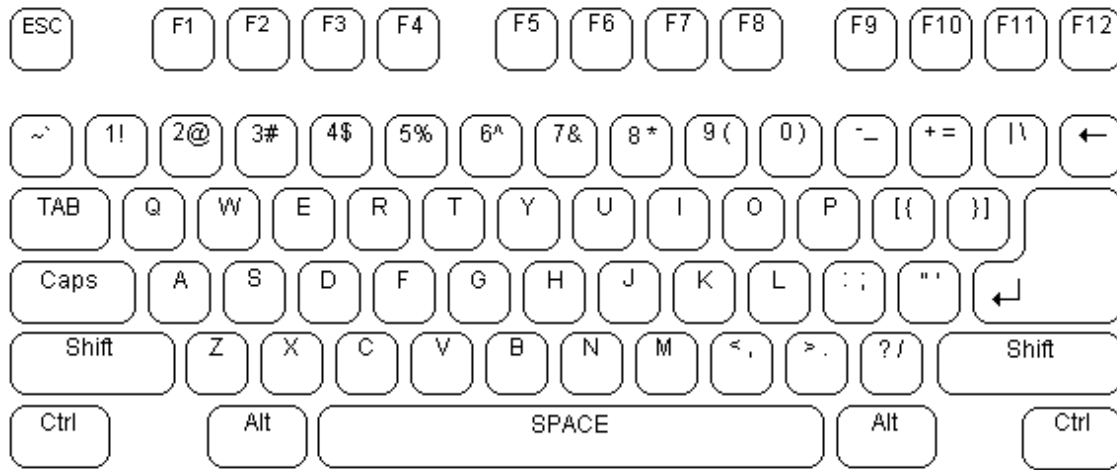

International English keyboard mapping. Standard for non-UK units.

The alphanumeric characters in the QWERTY section of the keyboard and the keys of the numeric keypad can be typed directly to the screen as would normally be expected. Each alphabetic character key is normally lowercase. Uppercase characters can be typed by holding down the shift key or pressing the CAPS LOCK key. The keyboard's LED indicators will not be lit by the unit. To exit CAPS LOCK mode press the key again.

When using the SHIFT, CTRL or ALT control keys in conjunction with the alphabetic or the function keys the control key must be pressed first, then the required alphabetic or function key must be pressed and released, before the control key is released. If the SHIFT, CTRL or ALT key is pressed or released simultaneously with another key then the correct control function may not be recognised by the unit. If you find that the unit behaves as if one of the SHIFT, CTRL or ALT control keys were still being pressed, use the ESC key to clear the setting. If the unit fails to respond to the keyboard while the cursor is flashing onscreen, wait until the cursor times out and disappears, then start typing again.

To remove a character from the screen use the backspace key. This will replace the character immediately to the left of the current cursor position with a blank space and move the cursor to that position. The Delete key has no function. The Home and End keys move the cursor position to the left and right of the current line on the screen. The Return key moves the cursor to the beginning of the next line.

Each text character can be displayed with a background, blink and / or an invert attribute. These attributes can be set to control how the text characters are displayed using the F1 & F2 keys as shown in the command table below. Once set each attribute is applied to all characters subsequently typed until the attribute is unset. Each attribute affects each character which is typed while it is set individually.

The video text overlay unit operates in two modes. In the first mode the text is overlaid over the video input signal. When the video signal is removed the unit automatically switches to generating its own internal dark grey background video signal and will switch back to the external video when this is reconnected. In the second mode the unit generates its own video signal internally, but ignores the external video signal. All keyboard commands operate in the same way in both modes. To switch between modes use the F3 key as shown in the command table below. Each page can have this mode set independently.

CTRL	F1	Free cursor to full display extents
ALT	F1	Lock cursor to visible display extents
SHIFT	F1	Turn the background setting off
	F1	Turn the background setting on
CTRL	F2	Turn the invert setting off
ALT	F2	Turn the invert setting on
SHIFT	F2	Turn the blink setting off
	F2	Turn the blink setting on
SHIFT	F3	Select text over internal video signal
	F3	Auto select text over external / internal video

Command Table 1. Background, blink attribute and display mode selection

The OSD is specified as being able to display 30 characters by 16 rows in PAL and 30 characters by 13 rows in NTSC. However on a normal CRT monitor you will only be able to display 26 characters by 14 rows in PAL or 26 characters by 11 rows in NTSC. On an LCD panel monitor which gives close to the full video frame you will be able to see approximately 28 characters by 15 rows in PAL or 26 characters by 12 rows in NTSC. By default the cursor is locked to the visible extent of the display for a CRT. This can be changed using the F1 function key command if you are using an LCD monitor. The position of the display can be controlled with the F7 command. This allows the visible text display to be moved up and down, left or right so that it can be positioned as desired on the monitor. The display position can be restored to its defaults with the F8 command.

The video text overlay unit divides its display between eight on screen pages. Text written to each of these pages is will be stored in the unit's non-volatile memory until overwritten. There is no default on screen indication of which page is currently selected. To move between the screen pages use the page up and page down keys or the F10 function key command. Page up moves toward page 1. Page down moves toward page 8. To clear the screen page of text press F9. The character white level, or brightness, of all the characters displayed can be adjusted via the F11 commands. The setting is stored by the unit. When the unit is turned on the character white level will default to that set previously.

CTRL	F7	Shift display down
ALT	F7	Shift display up
SHIFT	F7	Shift display left
	F7	Shift display right
	F8	Reset display X - Y position
	F9	Clear the screen

Command Table 2. Screen setting control

CTRL	F10	Page down
ALT	F10	Page up
SHIFT	F10	Not used
	F10	Enter prescale set mode
CTRL	F11	Character white level 1 (darkest)
ALT	F11	Character white level 2
SHIFT	F11	Character white level 4 (brightest)
	F11	Character white level 3 (default)
	F12	Outline screen
	ESC	Clear SHIFT↑, CTRL, ALT and CAPS settings

Command Table 3. Screen setting control

Outlining

As well as text characters the video text overlay unit is able to generate characters to outline areas of the screen. Like the text characters, these are stored on each page until they are deleted. The outline characters are accessed using the ALT key and the character key as shown in the outline character command table below. In addition to manually outlining specific areas, the central area of the screen display can be outlined using the F12 command. This also places a cross hair in the approximate centre of the screen.

ALT + A	┌	Top left corner
ALT + B	┐	Top right corner
ALT + C	└	Bottom left corner
ALT + D	┘	Bottom right corner
ALT + E	=	Top outline
ALT + F	=	Bottom outline
ALT + G		Left outline
ALT + H		Right outline
ALT + I	┆	Mid left
ALT + J	┆	Mid right
ALT + K	┆	Mid top
ALT + L	┆	Mid bottom
ALT + M		Mid vertical line
ALT + N	=	Mid horizontal line
ALT + O	+	Full cross
ALT + P	-	Left cross hair
ALT + Q	+	Centre cross hair
ALT + R	-	Right cross hair
ALT + S	□	Box
ALT + T	=	Top left outline
ALT + U	=	Top right outline
ALT + V	=	Bottom left outline
ALT + W	=	Bottom right outline

Command Table 4. Outline characters



Result of F12 Outline Command

Time & Date

To set the time and date, press F4. The seconds element of the time will flash. Press the left arrow to cycle through the elements of the time and date. To increment the element selected press the up arrow key. To leave the time set mode press return. There is no protection for the time display area, it overwrites anything you put into that space with the keyboard. The clock can be displayed with the counter on a single line either at the top or bottom of the screen. The display is alternated between these positions by pressing F5. The clock can be hidden by pressing CTRL+F4, and displayed when hidden by pressing SHIFT+F4. Press ALT+F4 to toggle the clock and counter background on and off. This background setting does not affect the background setting for typed text.

ALT	F4	Toggle the background of the time, date and counter
CTRL	F4	Hide the clock display
SHIFT	F4	Show the clock display
	F4	Enter time set mode
	RETURN	Exit time set mode
	LEFT ARROW	Select time or date element
	UP ARROW	Increment the time or date element
	F5	Alternate the clock display between 2 screen positions

Command Table 5. Time & Date Display mode selection

Counter

The counter is driven by a rising edge on RB6 as shown on the pin out diagram. The input is 0V to 5V TTL logic and must be protected from external voltage levels, if different. The direction of the count is determined by the state of RB7. If the pin is TTL high then the count is positive. If it is TTL low then the count is negative. The direction pin is pulled high internally to give a positive count by default. The counter increments / decrements by 1 between +9999 and -9999. The position of the decimal point in the count display can be changed to one of four positions by pressing ALT+F6 as shown in table 6 below. The change in the decimal point position does not change the value of the count or change the prescale constant value.

A prescale constant between 1 and 2048 can be set to allow the counter display to be adjusted to match the external count source. To set the prescaler first press F10. This puts the unit into prescale setting mode. The count displayed will be replaced on screen by the flashing prescale constant preceded by a colon : to indicate this is the prescale constant. The right cursor key increments the prescale constant by 1. The up cursor key increments the prescale constant by 10. The left cursor key increments the prescale constant by 100. The down cursor key resets the prescale constant to 0001. Pressing return leaves the prescale setting mode and stores the changed value in EEPROM. Pressing ESC leaves the prescale setting mode without storing any changes.

Please note that the counter is not a direct distance measurement. You will need to know the counts per turn and turns per unit of distance measurement given by the encoder used to set the prescale to read the display. The counter value is preserved when power is removed from the unit.

ALT	F6	Change decimal point position 0000→0.000→00.00→000.0
CTRL	F6	Hide the counter display
SHIFT	F6	Show the counter display
	F6	Clear the counter to +0000

Command Table 6. Counter control commands

	F10	Enter prescale set mode
	RETURN	Exit prescale set mode and save changes
	ESC	Exit prescale set mode and discard changes
	RIGHT ARROW	Increment prescale value by 1
	UP ARROW	Increment prescale value by 10
	LEFT ARROW	Increment prescale value by 100
	DOWN ARROW	Reset prescale value to 0001

Command Table 7. Prescale set commands

Connections

If you purchase the board only option you will need to make connections for power, video and keyboard as shown below. Please note that your warranty specifically excludes failure due to improper connection so you should take care and follow the instructions below. The keyboard and counter connection points are as shown below left. Note that the keyboard data connection is to RB3, not RB1 as it was on previous versions of the unit. Both keyboard and counter signal levels are 5V TTL logic.

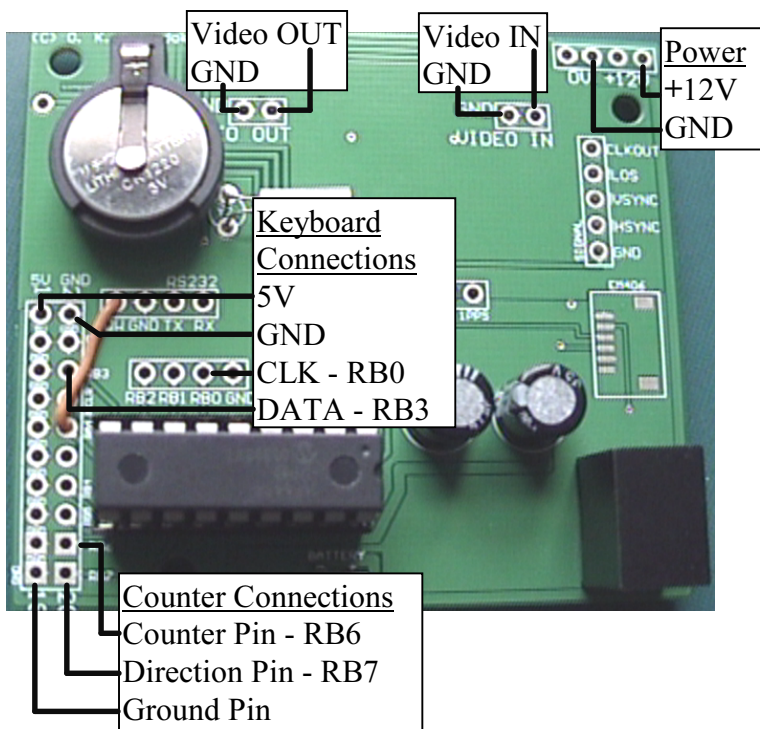

Keyboard and counter connection points on the board

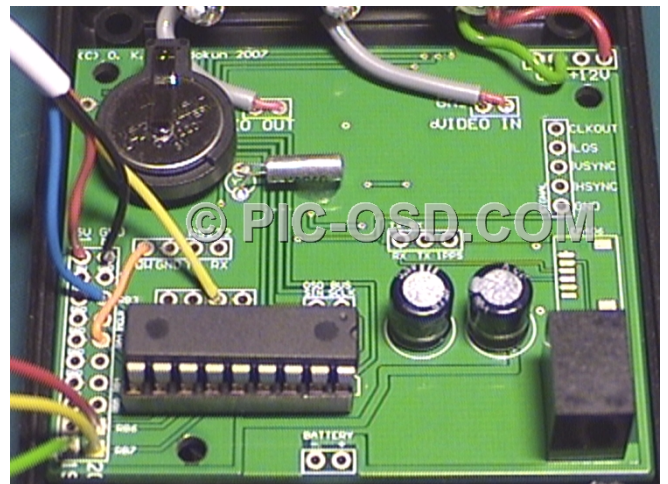

The board with connections made



Pin	Signal
1	No connection
2	5V
3	No connection
4	DATA
5	GND
6	CLK

PS/2 Connector socket pin out, looking into the connector.

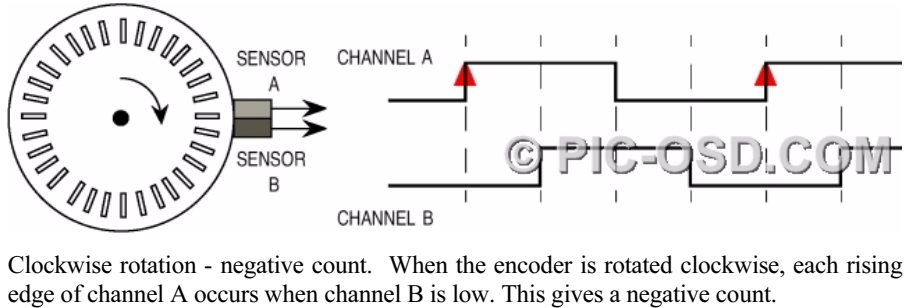
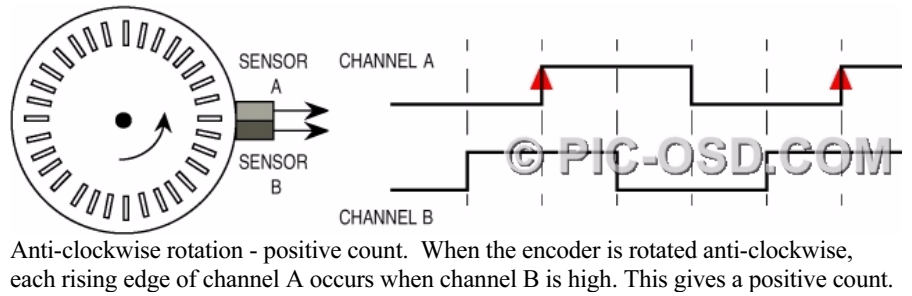
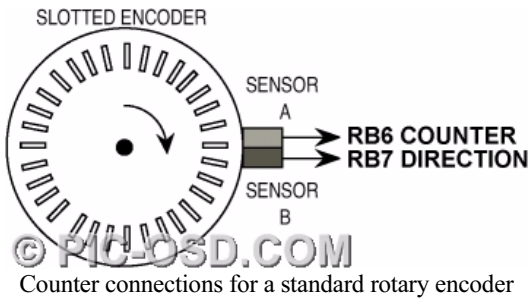

**PS/2
connector**

**counter
connector**



The counter connector is a 3.5mm jack socket. Both the video overlay unit and external circuit should be disconnected from power when you are inserting or removing the 3.5mm jack plug.

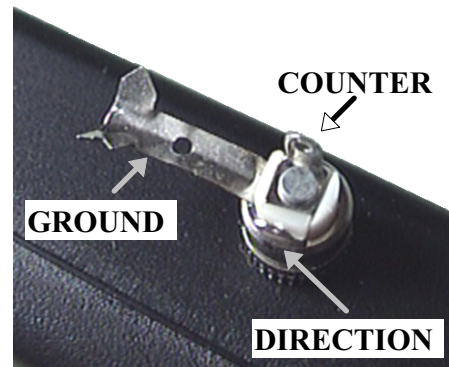

The external circuit should be connected to the overlay unit using the right angle 3.5mm jack plug supplied. The 5V TTL connections are:
Tip counter
Middle direction
Base ground



The counter can be reset either from the keyboard or from the reset button on the unit.

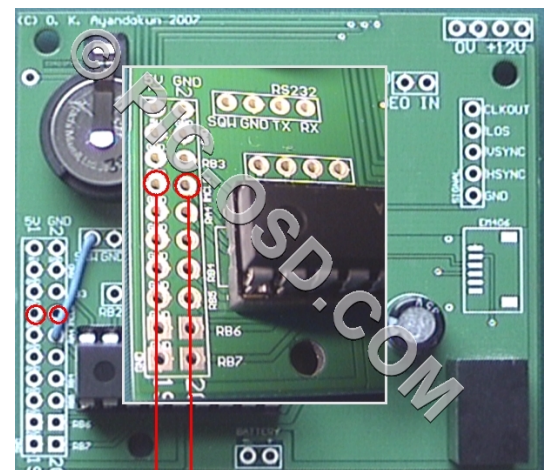

**Counter Reset
Momentary push button
!MCLR - GND**

WARRANTY

The BlackBoxCamera™ Company Ltd. warrants its products to be free of defects in materials and workmanship under normal use and service for a period of twelve months from the date of original purchase. The obligations of The BlackBoxCamera™ Company Ltd. shall be limited within the warranty period, at its option, to repair or replace the product or any part thereof. The company shall not be responsible for dismantling and/or installation charges. To exercise the warranty the product must be returned carriage paid and insured. Under this limited warranty the maximum liability of The BlackBoxCamera™ Company Ltd. shall not in any case exceed the purchase price of the product, which shall be fixed as liquidated damages and not as a penalty, and shall be the complete and exclusive remedy against The BlackBoxCamera™ Company.

This warranty does not apply in the following cases: Improper installation, misuse, failure to follow installation and operating instructions, alteration, abuse, accident or tampering, and repair by anyone other than The BlackBoxCamera™ Company.

The BlackBoxCamera™ Company Limited, Moorgate House, 5 - 8 Dysart Street, London, EC2A 2BX, UK

Phone: 0844 504 7934

Fax: 0844 504 7935

EMAIL: sales@pic-osd.com

www.pic-osd.com

